



Earnings Presentation

Earnings Announcement: April 15, 2026



免責聲明/Safe Harbor Notice

- 瀚荃對目前期望的陳述是前瞻性陳述，受到重大風險和不確定性的影響，實際結果可能與前瞻性陳述中包含的內容有重大差異。
- 有關可能導致實際結果變化的因素的資訊，可在瀚荃向台灣證券交易所公司（TWSE）提交的年度或季度報告，以及瀚荃不定時向TWSE提交的其他文件中找到。
- 除非法律有要求，否則我們不承擔更新任何前瞻性陳述的義務，無論是因為新資訊、未來事件或其他原因。
- 此份報告的數字是按照國際財務報導準則（IFRS）編制的。

01 Business Units/Operations & Manufacturing

02 Revenue Mix by Product

03 Financial Highlights

04 Future Growth Strategy

05 Q & A

Agenda

事業群

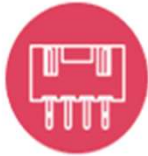

連接器事業群

Connectors
Business Unit



70%



線纜組件事業群

Cable & Harness
Business Unit



25~
30%



電子配件事業群

Accessories
Business Unit









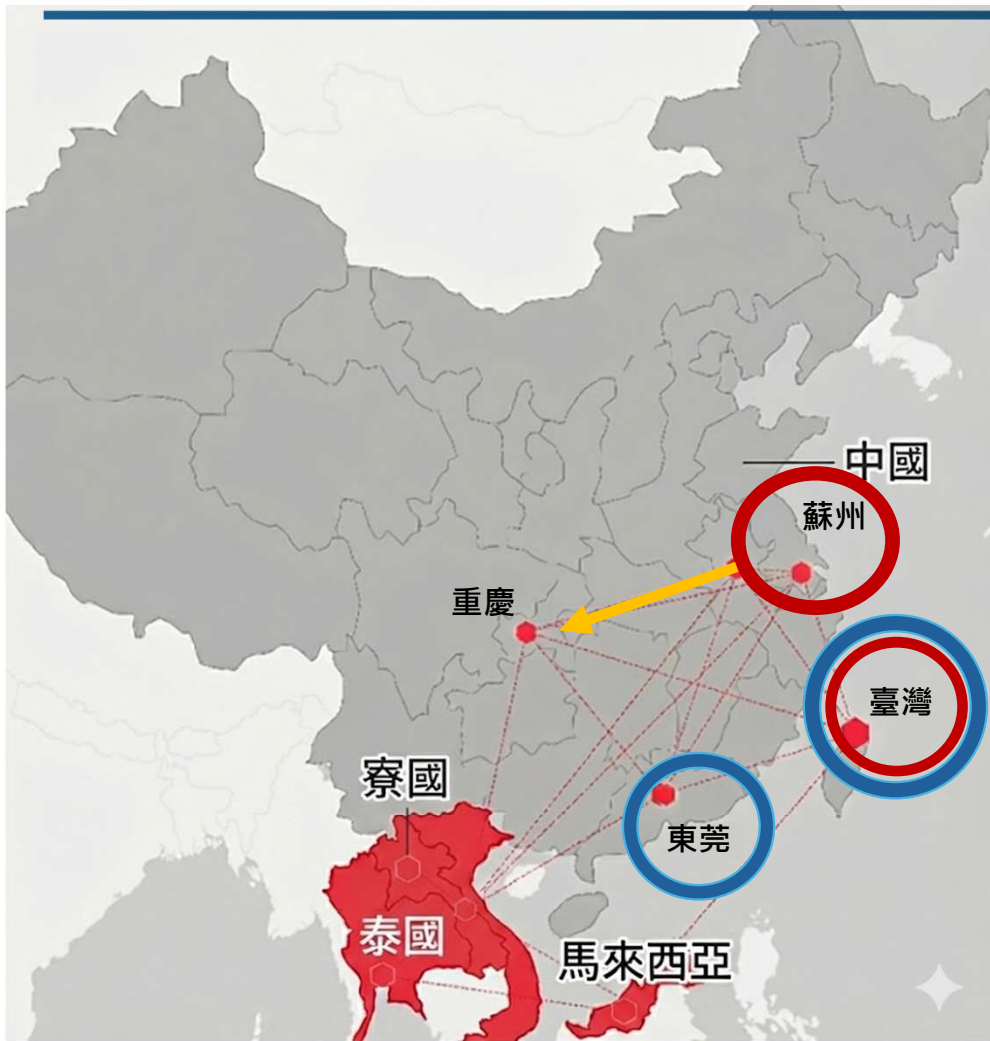

>5%

營運據點&產線分佈



產能擴張與資源重新分配



 營運總部	瀚荃股份有限公司 (台北)	150	Automatic machine Software Center
 華南廠一廠	瀚荃電子東莞 (東莞)	700	Power Connector、Harness、FFC、 Wireless、Module / Sensor
 華南二廠	東莞群翰電子 (東莞)	300	Lightning / Type C、I/O connector Insert molding
 華東廠	瀚荃電子科技 (蘇州)	350	Fine Pitch Connector FFC / FFC LVDS
 華西廠	瀚荃電子科技 (重慶)	350	FFC / FFC LVDS
 寮國廠	瀚荃寮國廠區 (老撾)	250	Wire Drawing Type C cable
 越南廠	瀚荃越南廠區 (越南)	10	Wire Board connector I/O connector
泰國廠 馬來西亞			計畫中

2025 損益表

(仟元/新台幣)

	2025 Q4	2024 Q4	YOY	2025	2024	YOY
營業收入 Net Sales	891,947	829,291	8%	3,355,450	3,188,144	5%
營業成本 Cost Of Goods Sold	542,875	489,569	11%	2,100,106	2,079,718	1%
營業毛利 Gross Profit	349,072	258,722	35%	1,255,344	1,108,426	13%
毛利率%	39%	31%		37%	35%	
營業費用 Operating Expenses	246,049	201,567	22%	805,880	743,778	8%
費用率%	28%	24%		24%	23%	
營業淨利 Operating Income	103,023	57,155	80%	449,464	364,648	23%
營益率%	12%	7%		13%	12%	
業外收支 Total Non-Op. Inc&Exp.	39,776	75,882	-36106	34,851	139,804	-104,953
稅前淨利 Earnings Before Tax	142,799	132,967	7%	484,315	504,452	-4%
所得稅 Income Tax Expense	26,090	47,615	-45% (18%)	145,801	166,830	-13% (30%VS.33%)
稅後淨利 Net Income	116,709	85,352	37%	338,514	337,622	0%
每股盈餘 Earnings Per Share	1.45	0.93	56%	3.92	3.96	-1%

Q4 25 Revenue Mix by Product

2025 Q4 產業佔比

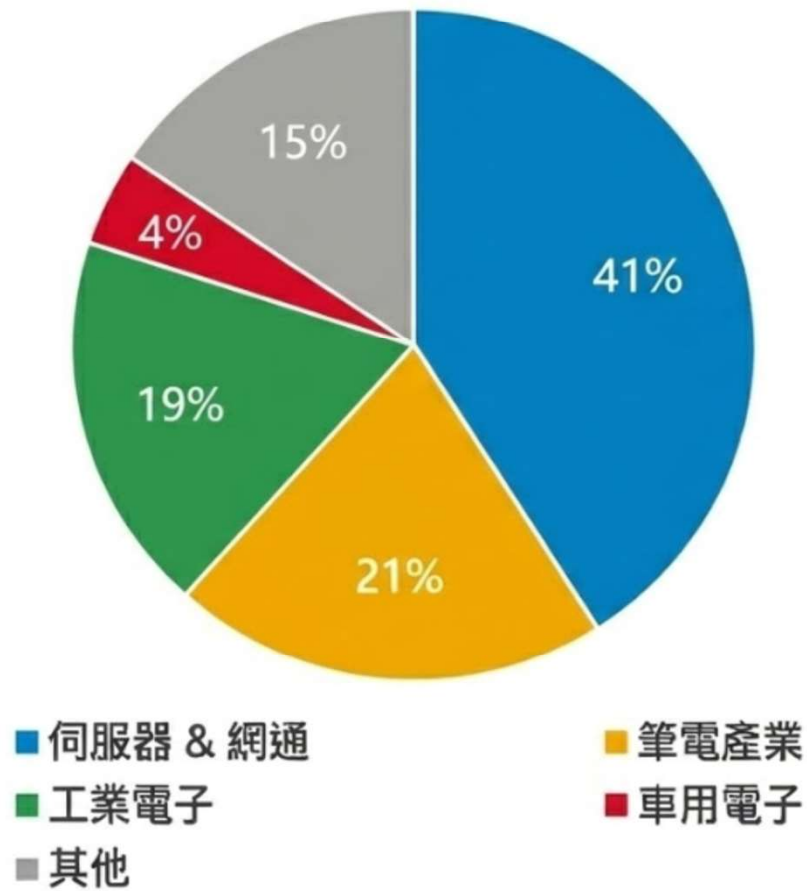

QOQ 成長率

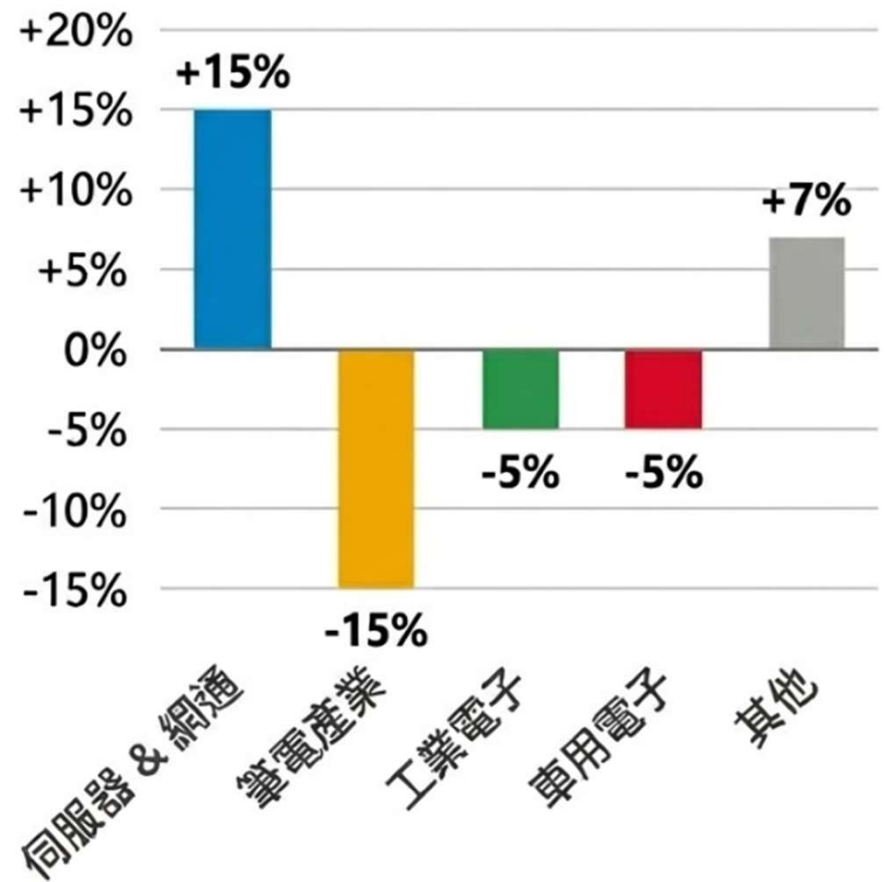

Q4 25 產品組合

	2024Q4	2025 Q3	2025 Q4	QOQ	YOY
伺服器 & 網通 (AI Power)	36% (10%)	37% (16%)	41% (19%)	+15% (+22%)	+20% (115%)
筆電產業	23%	24%	21%	-15%	-6%
工業電子	19%	21%	19%	-5%	+7%
其他	19%	14%	15%	+7%	-2%
車用電子	4%	4%	4%	-5%	+4%

2025 產品組合

	2024	2025	YOY
伺服器 & 網通 (AI Power)	34% (8%)	37% (18%)	+14% (135%)
筆電產業	24%	23%	0%
工業電子	18%	20%	+13%
其他	19%	16%	-8%
車用電子	5%	4%	-14%

產品毛利分佈

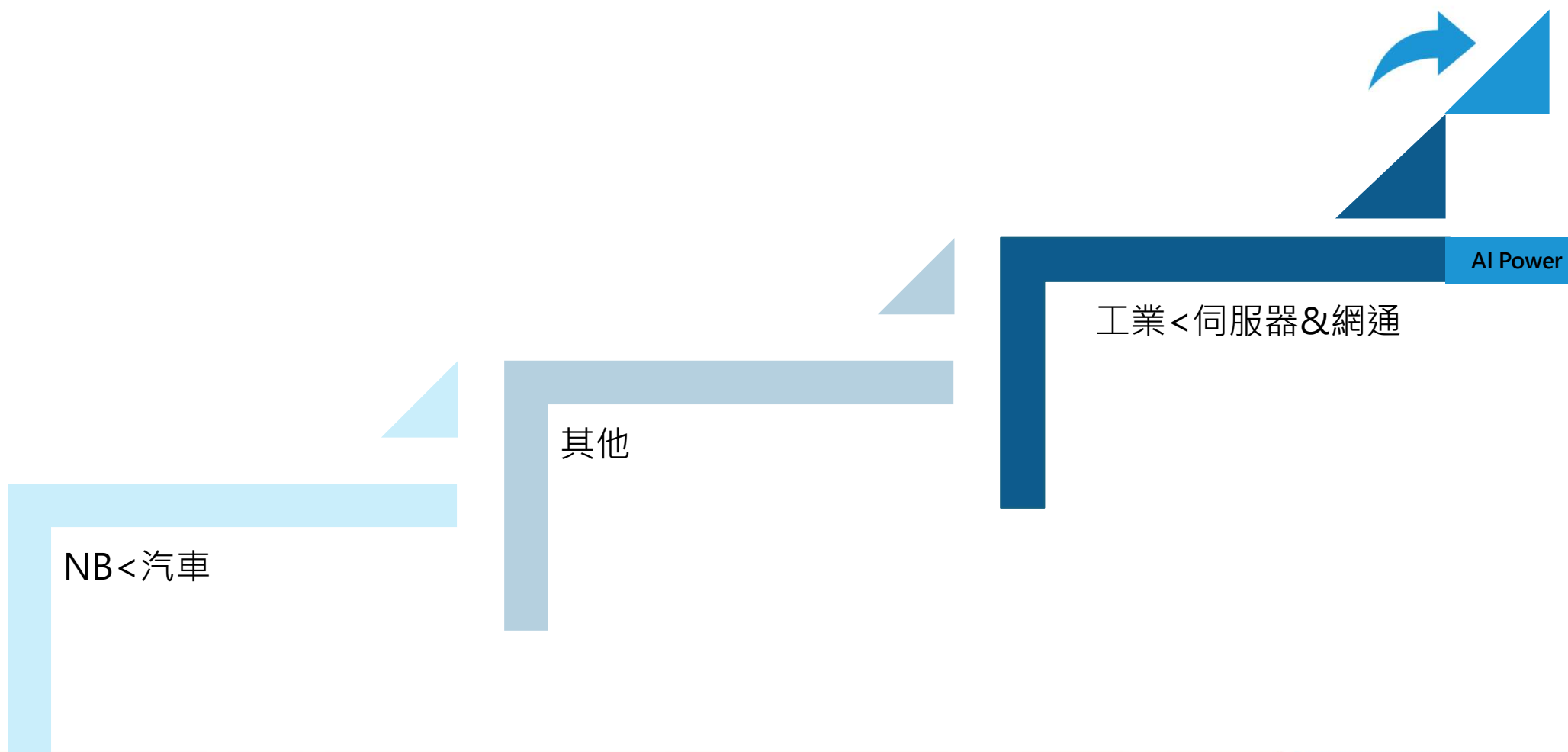

AI 相關成長曲線

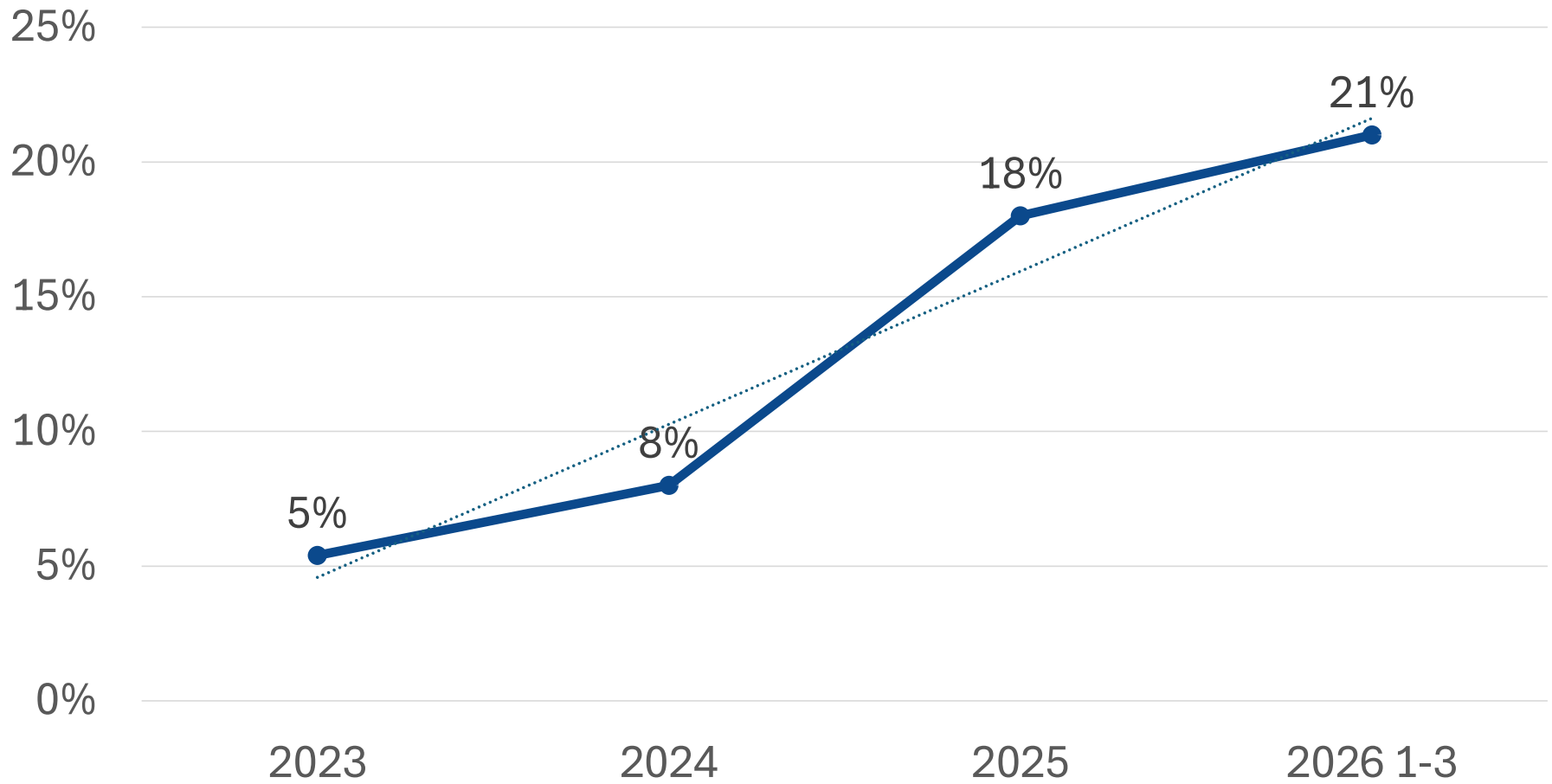

AI 重要客戶動能

客戶/年	2023	2024	2025	2026
A	3%	4%	6%	8%
B	2.5%	3%	7%	8%
C	1%	1%	3%	4%
Others	0%	1%	2%	1%
Total	6.5%	8.5%	18%	21%

受惠電力產業路徑

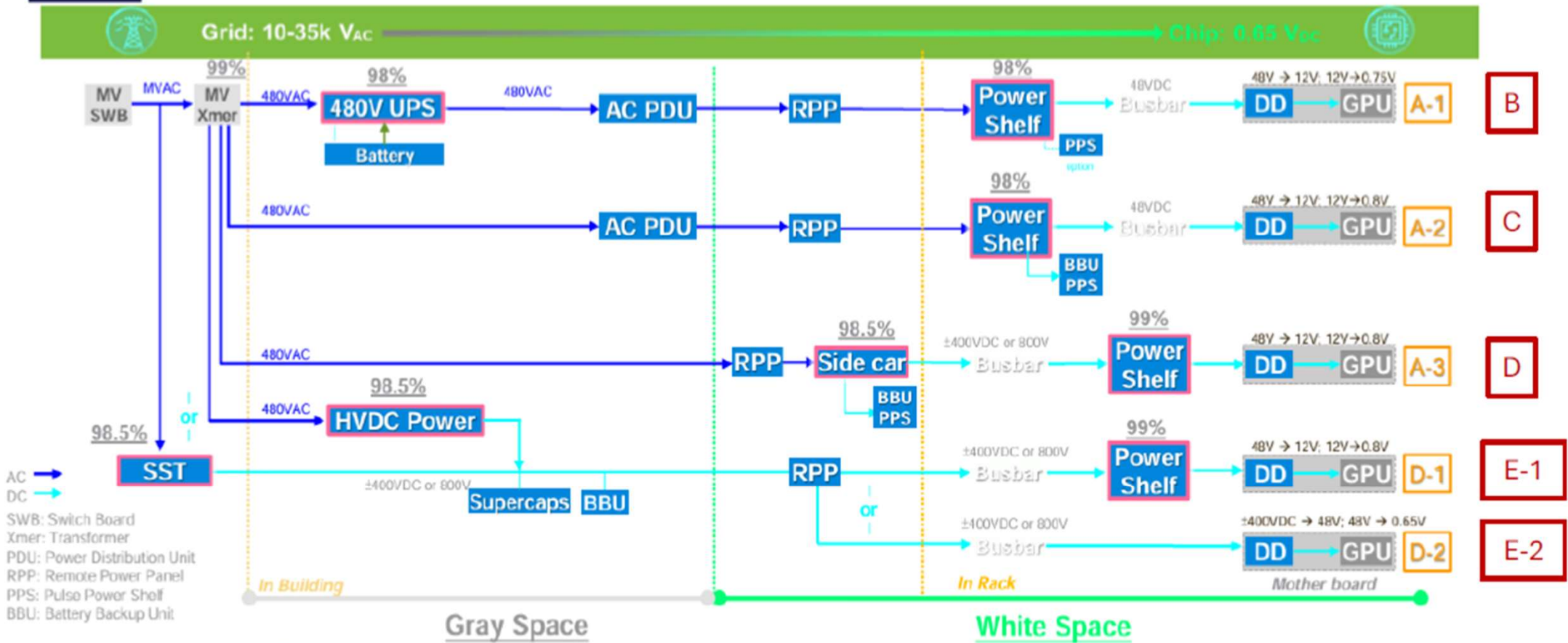

• 1~1.5% higher efficiency @ full load

• DC Bus provide RE/ESS integration capability
• Grid function support

• HVDC bus voltages for scalability

Source:Nomura

2026 產品組合

(季)

	26年 Q1	25年 Q1	YOY
伺服器 & 網通 (AI Power)	44% (21%)	34% (20%)	+54% +(26%)
筆電	22%	24%	+10%
工業電子	16%	17%	+18%
其他	15%	20%	-10%
車用電子	3%	4%	+5%

營 運 展 望

➤ 趨勢催化產品升級

電力產業趨勢明確、緊追客戶專案開發。

➤ 產線精實

中國五減為三+擴增非中產能及自動化產能。

➤ 資產負債表管理。

資本支出(擴建新廠)、產業投資、股東回饋。



Q & A.

For more information, please
visit www.cvilux-group.com